



INNOVATIVE POWER AND SIGNAL DISTRIBUTION

HELLO **BUILDING**

Solutions for pluggable building installation
+ decentralized room automation.

- + BUILDING TYPES
- + REQUIREMENT PROFILES
- + APPLICATION SOLUTIONS

A man with brown hair and a goatee, wearing a dark grey suit jacket over a white collared shirt, is smiling slightly. He is holding a green multi-core cable with a black connector in his right hand. The background is a bright, out-of-focus indoor setting.

“We offer **solutions** that impress.
That’s how we’ve become **world
market leader.**”

DIPL.-ING. (FH) THOMAS NIEBORG

Product Manager | Software and Tools

HELLO BUILDING

- 04** Pluggable decentralized building installation
- 06** Savings potential with decentralized installation
- 08** System overview + components
- 10** Installation areas + installation levels
- 12** BUILDING TYPE Offices + administration buildings
- 14** BUILDING TYPE Hotels
- 16** BUILDING TYPE Hospitals
- 18** BUILDING TYPE Retail/shops
- 20** BUILDING TYPE Retail/electronics + furniture stores + DIY stores
- 22** BUILDING TYPE Parking garages + warehouses + logistics + production
- 24** BUILDING TYPE Schools
- 26** Application solution: Infrastructure cabling
- 27** Application solution: Floor box supply
- 28** Application solution: Cable Tray supply
- 29** Application solution: Lighting cabling (switched)
- 30** Application solution: Lighting cabling (regulated)
- 31** Application solution: Lighting cabling (switched centrally, 1/3 circuit)
- 32** Application solution: Decentralized room automation (KNX, FanCoil, EnOcean)
- 33** Application solution: Decentralized window blinds control (relay, SMI)
- 34** Servicing & services
- 35** General information + contacts



SMART SOLUTIONS FOR BUILDING PLANNERS + ARCHITECTS.

As an experienced and reliable partner, we can help you satisfy your building requirements with safety, efficiency, and pluggability. For over 40 years, we have been offering smart solutions with our connector systems, whether for lighting installation and automation, room automation, power supplies, and more.

Short timelines and tight completion schedules are the norm for on-site electrical installers. That is why a quick, safe, and above all faultless electrical installation is necessary.

Additionally, changes during the construction phase or ongoing operation require products that can offer a high degree of flexibility. Our modular gesis® system meets all these requirements and is impressively easy to use.



ECONOMIC PLANNING

gesis® ensures that schedules and project flows can be calculated accurately and guarantees standardized quality in planning and execution.



SUSTAINABLE PROCESS & QUALITY

gesis® is the standardized interface for all building installation and automation jobs. The mechanical coding reliably prevents mismatching.



QUICKER ASSEMBLY

Pluggable components minimize assembly times thanks to a well-conceived interface technology and a diversified connection technology with prefabricated cable sets.

THE SYSTEM FOR:

- + OFFICES
- + HOTELS
- + HOSPITALS
- + SCHOOLS
- + RETAIL SHOPS, MARKETS, FURNITURE STORES
- + PARKING GARAGES
- + PRODUCTION FACILITIES
- + STORAGE AREAS
- + HALLS
- + ADMINISTRATION BUILDINGS

TAKE ADVANTAGE OF TIME AND COST SAVINGS WITH **DECENTRALIZED + PLUGGABLE** INSTALLATION.

Cabling based on smart installation concepts creates clean installation structures. In combination with pluggability, this leads to a system that can be installed quickly and safely. Additionally, voltage drop is reduced and energy efficiency is increased through consistent three-phase cabling up to the load.

INSTALL SMARTLY – UNLIMITED POTENTIAL

With our gesis® installation system, we have revolutionized electrical installation. High-quality and durable components boast an impressive 70 % time and 30 % cost savings! gesis® has been conceived as a modular system: all of the product groups complement each other and enable smart and cost-effective electrical installation, from the distribution point to the load.

By opting for a gesis® flat cable system you can benefit from all the advantages of a smart electrical installation. You can install branches at any point and at any time, quickly and safely, without having to cut the cable! Contacts are made by means of insulation-piercing connection technology. Five systems are available to you with different cross sections, regardless of whether you want to distribute power or signals.

Property-specific distribution boards for decentralized power supply and building automation complete our installation system.

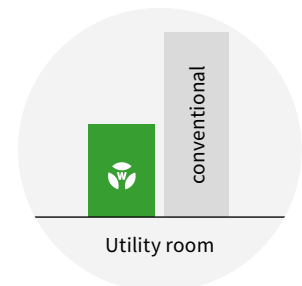
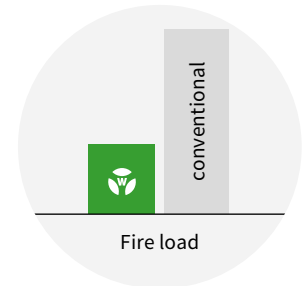
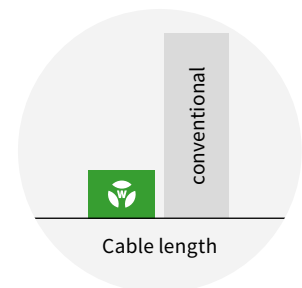

YOUR BENEFITS

- + More usable space
- + 30 % lower installation costs
- + Power available wherever and whenever easily – quickly – safely

REDUCE COSTS WITH **DECENTRALIZED** BUILDING AUTOMATION.

Buildings have to be energy-efficient, easy to use, safe, and adaptable. Automation components are not only effective but also quick to install and easy to handle. With sophisticated and future-proof products, we provide solutions to meet all of your building automation requirements.

PLAN EFFICIENTLY + COST-EFFECTIVELY

Smart building automation sustainably reduces a building's energy needs, so investments in automation technology pay for themselves in just a few years.

With our smart installation components, we take the basic idea of a bus-based system and combine it with pluggability to create a highly flexible system. Any later changes of use throughout the lifecycle of the building can be implemented easily.

Our decentralized + pluggable products demonstrate their full added value in terms of speed and lasting cost effectiveness especially with projects involving a large number of identical rooms, such as hospitals, hotels, offices, and administration buildings.

YOUR BENEFITS

- + Reliably calculable project timelines & cost
- + Easy planning – clean structures
- + Flexible room configuration now and in the future – safely



OVERVIEW DECENTRALIZED ELECTRICAL INSTALLATION

gesis® + RST® SYSTEM PRODUCTS

FEATURES OF PLUGGABILITY:

- Quick installation.
- Safe installation.
- Structured cabling.
- Low error rate.
- World market leading quality and preassembly.
- Flexible modular system.
- Reusable.
- Extendable.

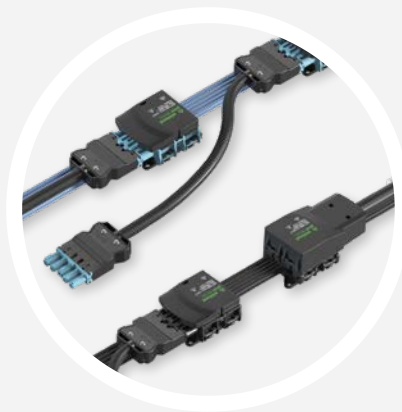

gesis® NRG

Flexible busbar for efficient infrastructure cabling.



gesis® RAN

Project-specific system distribution unit for smart installation.



gesis® CLASSIC

Pluggable electrical installation for floor boxes, lighting, etc.

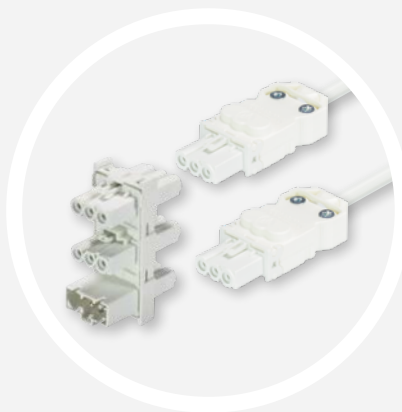

gesis® MINI

Size-optimized version for limited space.



RST® CLASSIC/RST® MINI

IP-protected electrical installation for outdoor areas.

COMPONENTS **OVERVIEW**

DECENTRALIZED **ROOM AUTOMATION**

gesis®ELECTRONIC

SYSTEM FEATURES:

- Universally usable components.
- Can be equipped individually.
- Safety (in part fully functional during a bus failure).
- Adaptable to change of use.
- Fit for the future.



gesis® FLEX

Modular, project-specific system for KNX.



gesis® RC

Radio technology without batteries for wireless sensors.



gesis® FLEX

Decentralized KNX system for sustainable room automation.

GESIS® SMART EFFICIENT VERSATILE

In 2018, Wieland Electric was crowned as the world market leader in pluggable installation solutions for functional buildings by the magazine Wirtschaftswoche.

Our gesis® modular system offers optimized pluggable solutions for all applications, from building infrastructure to luminaire connection and through to energy-efficient building automation.

We are already thinking about the functionality and future viability of our components so that gesis® remains the system with pluggable added value in the future as well.

**We bring energy
into every space!**



DESIGN PLUS

powered by: **light+building**



**GERMAN
DESIGN
AWARD
2017**



**DESIGN
AWARD
2016**

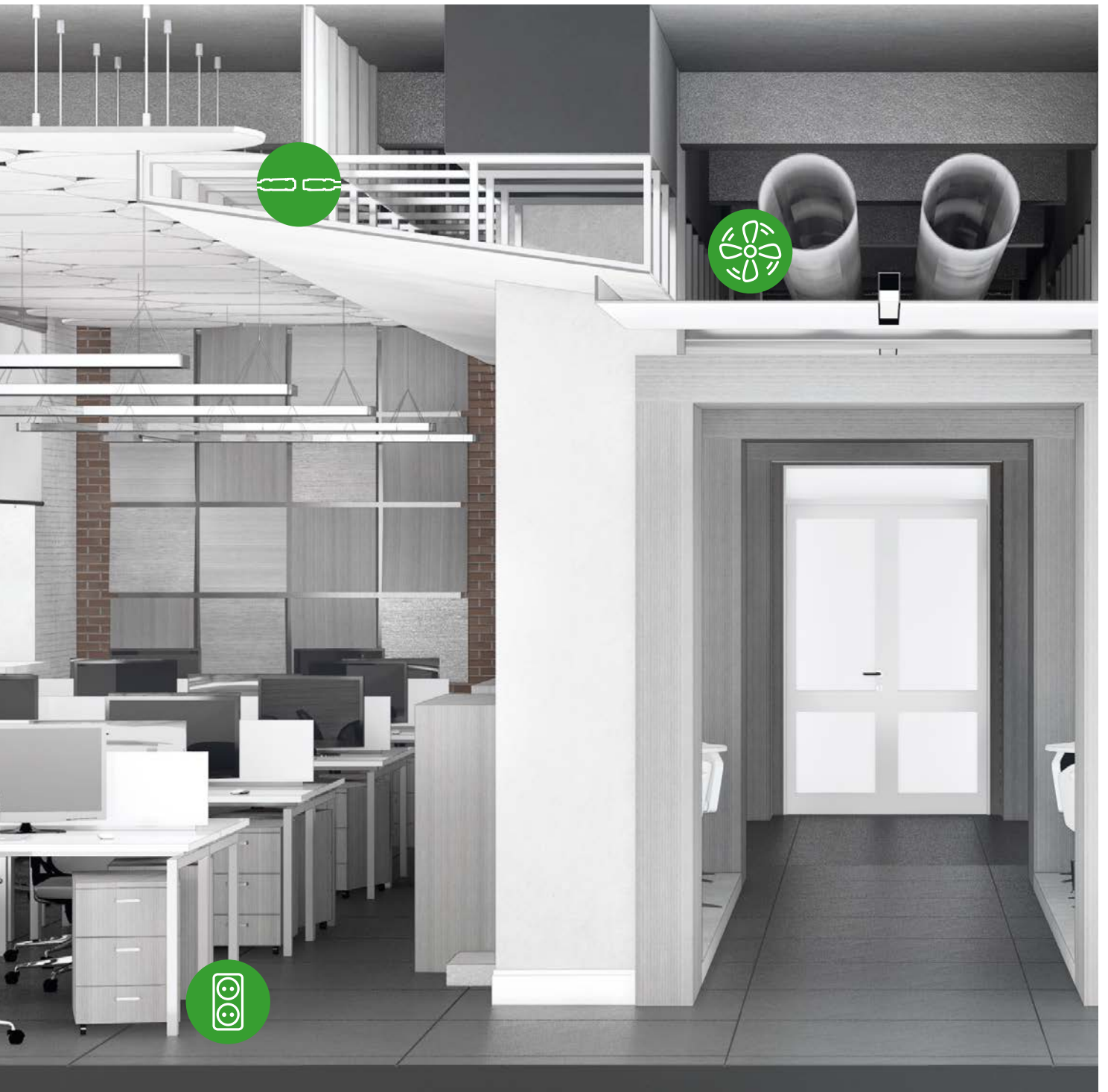

THE SYSTEM IS USED FOR

- ▶ Infrastructure cabling
- ▶ Floor box supply
- ▶ Cable tray
- ▶ Lighting, switched, regulated, controlled (DALI)
- ▶ Decentralized room automation (KNX)
- ▶ Window Blinds (KNX, relay, SMI)
- ▶ FanCoil (KNX)
- ▶ EnOcean (KNX)
- ▶ Cabling in lightweight/modular walls
- ▶ Installation column



OFFICES + ADMINISTRATION BUILDINGS



FLOOR BOX CABLING

The different versions of the gesis®NRG flat cables supply floor boxes with and without decentralized fuse protection.

LIGHTING (REGULATED)

Comprehensive mains and DALI signal coverage for offices means that changes and extensions can be realized without any effort.

DECENTRALIZED ROOM AUTOMATION

The modular, decentralized, and directly pluggable systems can be extended and adapted quickly and easily to satisfy a change of use.



REQUIREMENTS

- Flexible office layout.
- Quick restructuring without any installation effort.
- High user comfort.
- Clear interfaces up to inside the desk.



SOLUTIONS

- Industrially prefabricated components.
- Flexible flat cable systems for easy extendability.
- Modular, easily adaptable room automation.
- Easy to plug together on site.



ADVANTAGES

- Fast, easy, and safe installation.
- Standardized interfaces for easy replacement.
- High functional reliability and error prevention due to coded plug system.

WINDOW BLINDS

Decentralized control and automation of window blinds drives offers huge savings potential with regard to the cables to be laid.

OFFICE FURNITURE CABLING

The pluggable electrical installation can also be continued into the furniture, creating clear interfaces and providing safety.

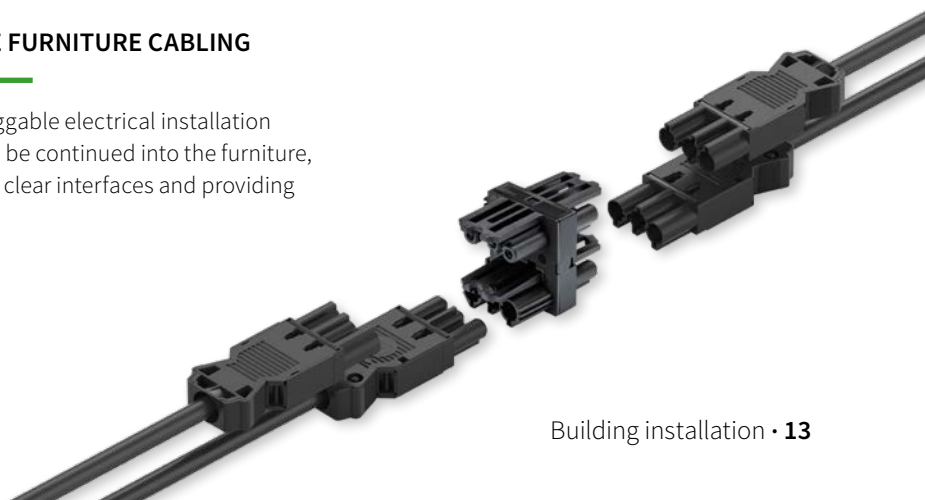



HOTELS



INFRASTRUCTURE CABLING

Hotel rooms are supplied via a flexible busbar with a high core cross section, which ensures clear structures in the installation level of the corridor area.

WINDOW BLINDS

Decentralized control and automation of window blinds drives offers huge savings potential with regard to the cables to be laid.

DECENTRALIZED ROOM AUTOMATION

The decentralized, modular components can be mounted directly and without any additional housing, saving installation space in the local sub-distribution boards.



REQUIREMENTS

- Fast, easy, and safe installation.
- Easy to maintain.
- Quick replacement of faulty components.
- Brief (non-existent) downtime for rooms.



SOLUTIONS

- Industrially prefabricated components.
- Directly pluggable to end device.
- Set solutions for simple logistics.
- Easy to plug together on site.



ADVANTAGES

- Fast, easy, and safe installation.
- High functional reliability and error prevention due to coded plug system.
- Minimal downtime.

OPTIMIZED SOLUTION

LIGHTING (REGULATED)

Thanks to the pluggable design of the entire lighting system, any component can be replaced quickly, easily, and safely in the event of a fault.





HOSPITALS



INFRASTRUCTURE CABLING

Hospital rooms are supplied via a flexible busbar with a high core cross section, which ensures streamline structures in the installation level of the corridor area.

CABLE TRAY

The space-saving use of gesis®NRG flat cables inside cable trays allows for a pluggable installation throughout and maximum flexibility.

LIGHTING (SWITCHED)

Thanks to the pluggable design of the entire lighting system, any component can be replaced quickly, easily, and safely in the event of a fault.



REQUIREMENTS

- Fast, easy, and safe installation.
- Easy to maintain.
- Quick replacement of faulty components.
- Brief (non-existent) downtime for rooms.



SOLUTIONS

- Industrially prefabricated components.
- Directly pluggable end consumers.
- Set solutions for simple logistics.
- Easy to plug together on site.



ADVANTAGES

- Fast, easy, and safe installation.
- High functional reliability and error prevention due to coded plug system.
- Minimal downtime.

DECENTRALIZED ROOM AUTOMATION

The decentralized, modular components can be mounted directly and without any additional housing, saving installation space in the local sub-distribution boards.





RETAIL SHOPS



LIGHTING (CONTROLLED CENTRALLY)

The pluggable design of the entire lighting system and its supply via a flexible busbar results in streamline structures that are easy to maintain.

LIGHTING (REGULATED)

Installations are equipped for future requirements and changes thanks to the 7-pole flat cable design with 3-phase mains and DALI signal.



REQUIREMENTS

- Structured, flexible infrastructure.
- Safe and quick installation.
- Changes without any effort.
- Future-proof installation.



SOLUTIONS

- Industrially prefabricated components.
- Directly pluggable luminaires.
- Optimized site logistics.
- Easy to plug together on site.



ADVANTAGES

- Fast, easy, and safe installation.
- Clear structures as a basis for easy extendability.
- Replacement of faulty components by trained persons.





RETAIL FURNITURE STORES + ELECTRONICS + DIY STORES



INFRASTRUCTURE CABLING

Retail spaces are supplied via a flexible busbar with a high core cross section, which ensures that power is comprehensively available.

LIGHTING (CONTROLLED CENTRALLY)

The pluggable design of the entire lighting system and its supply via a flexible busbar results in streamline structures that are easy to maintain.



REQUIREMENTS

- High energy demands in the space.
- Changing energy priorities.
- Safe installation.
- Remodeling under own responsibility.



SOLUTIONS

- Industrially prefabricated components.
- Decentralized system distribution units for installing safety devices.
- Completely pluggable design up to the end device.
- Easy to plug together on site.



ADVANTAGES

- Fast, easy, and safe installation.
- Abundant availability of power.
- Smaller changes can be made by instructed persons.





PARKING GARAGES



OPTIMIZED SOLUTION

PARKING GARAGE LIGHTING (REGULATED)

Installations are equipped for future requirements and changes thanks to the 7-pole flat cable design with 3-phase mains and DALI signal.



OPTIMIZED SOLUTION

PARKING GARAGE LIGHTING (SWITCHED)

The pluggable design of the entire lighting system means that luminaires do not need to be opened on site anymore. This minimizes the complexity and time required for electrical installation.





WAREHOUSES + LOGISTICS + PRODUCTION



REQUIREMENTS

- High degree IP rating.
- Easy luminaire replacement.
- No opening of luminaires on site.



SOLUTIONS

- Industrially prefabricated components.
- Directly pluggable luminaires.
- Optimized site logistics.
- Easy to plug together on site.
- Coordinated production dimensions.



ADVANTAGES

- Fast, easy, and safe installation.
- Luminaires do not have to be opened on site.
- Safe function with manufacturer's guarantee.
- Replacement of faulty components by trained persons.





SCHOOLS



DECENTRALIZED ROOM AUTOMATION

The modular, decentralized, and directly pluggable systems can be extended and adapted quickly and easily to satisfy changing requirements.

WINDOW BLINDS

Decentralized control and automation of window blinds drives offers huge savings potential with regard to the cables to be laid.



REQUIREMENTS

- Upgraded technology.
- Optimized energy use.
- Protection against unauthorized access.



SOLUTIONS

- Industrially prefabricated components.
- Installation column as central assembly area.
- Installation column as link between floor and ceiling.
- Easy to plug together on site.



ADVANTAGES

- Fast, easy, and safe installation.
- Installation column arrives on site fully pre-wired.
- Utility rooms can be reduced in size.
- Technological modernization without interfering with the structure of the building.

INSTALLATION COLUMN

- “Autonomous” installation technology for every classroom.
- Can be maintained independently of other rooms.
- Facilitates energy related and digital revitalization.
- Available in many different veneer designs.

INFRASTRUCTURE CABLING

Structured power distribution in floor or ceiling

APPLICATION IN THESE
BUILDING TYPES:

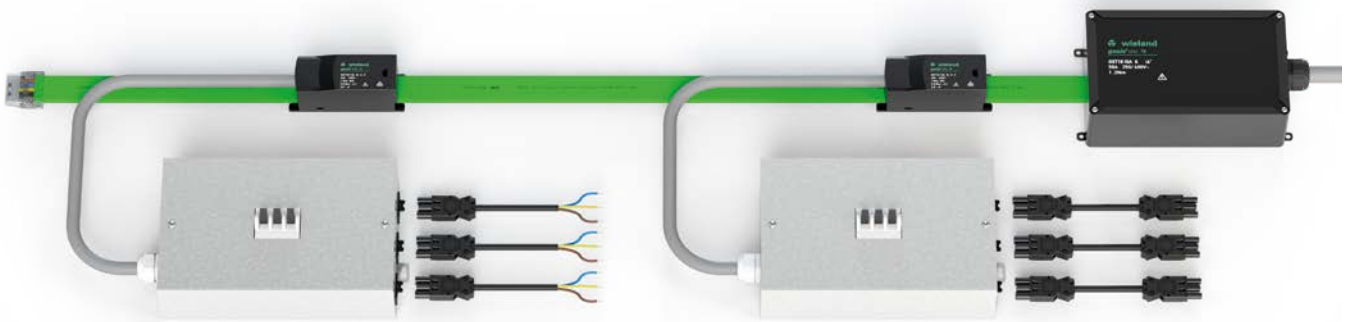

The gesis®NRG flat cable 5G10 mm² is particularly suitable for bringing energy into hotel, hospital, retail, and office spaces. It can be loaded with up to 50 A as a 3-phase system. The required safety devices for the output adapter and the connection cable are realized in a system distribution unit. Wieland also delivers the system distribution units with a connection cable already connected and a pre-assembled flat cable adapter. The rest of the installation can then proceed in an entirely pluggable fashion.

ENERGY

Power can be made available everywhere and in streamline structures.

INSTALLATION

There is no need for any laborious cutting, baring, stripping, or clamping of the cables.

OPTION

In the corresponding design with decentralized fuse protection, the gesis®NRG flat cable 5G10 mm² can also be used to supply floor boxes.

FLOOR BOX SUPPLY

Three-phase power supply up to just before the socket

APPLICATION IN THESE BUILDING TYPES:



The gesis®NRG flat cables 5G2.5/4 mm² are the ideal solution for structured supply to floor boxes. Three-phase power supply up to just before the floor boxes ensures reduced energy consumption. The availability of several cable colors makes it easier to distinguish between networks (NN/IT or general/emergency). The 3-pole, pluggable taps with free phase selection enable flexible load sharing. Floor boxes from various system partners are available as pluggable models straight from the factory. These can also be supplied with decentralized safety devices (MCB, RCBO) on request.



ENERGY

Three-phase power supply to the field reduces the voltage drop and saves energy.



INSTALLATION

There is no need for any laborious cutting, baring, stripping, or clamping of the cables.



OPTION

Using floor boxes from our system partners means that the entire floor installation can be made pluggable.

CABLE TRAY SUPPLY

Three-phase power supply up to just before the socket

APPLICATION IN THESE BUILDING TYPES:

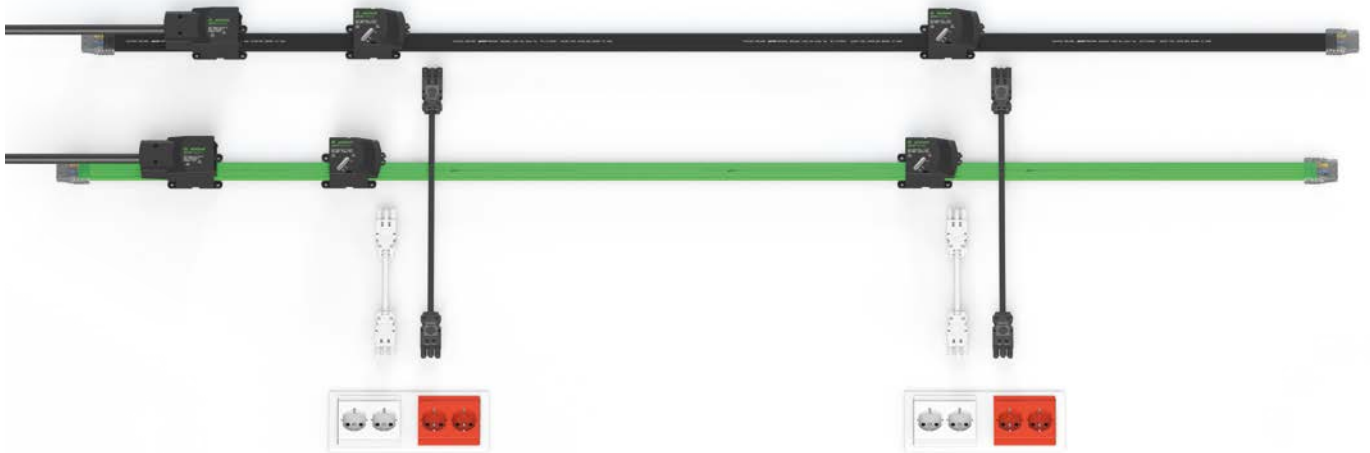

The gesis®NRG flat cables 5G2.5/4 mm² can also be used in cable trays thanks to the tap which is routed parallel to the cable. Three-phase power supply up to just before the socket ensures reduced energy consumption. The availability of several cable colors makes it easier to distinguish between networks (NN/IT or general/emergency). The 3-pole, pluggable taps with free phase selection enable flexible load sharing.



ENERGY

Three-phase power supply to the field reduces the voltage drop and saves energy.



INSTALLATION

There is no need for any laborious cutting, baring, stripping, or clamping of the cables.



OPTION

Using cable tray sockets from our system partners means that the entire cable tray installation can be made pluggable.

LIGHTING CABLING (SWITCHED)

Pluggable from the power supply to the luminaire

APPLICATION IN THESE BUILDING TYPES:



With gesis®CLASSIC the entire lighting system can be made pluggable. Where necessary, switches or buttons can also be plugged in using switch modules. This allows a flexible choice of connection technology for the luminaires.



SAFETY

With directly pluggable luminaires there is no need to open them for electrification. This means that the industrial manufacturing standard can also be maintained on site.



INSTALLATION

Thanks to the completely pluggable design of the installation, there is no need for any cutting, baring, stripping, or clamping of the cables. This speeds up the installation process enormously.



OPTION

Switches and buttons for local operation can be integrated via switch modules.

LIGHTING CABLING (REGULATED, DALI OR 1-10 V)

Power and dimming signal for the area

APPLICATION IN THESE BUILDING TYPES:



With gesis®NRG in combination with gesis®CLASSIC, it is extremely simple to supply DALI luminaires, for example. This allows a flexible choice of connection technology for the luminaires. With applications over a large area with long cable lengths, a 7-pole gesis®NRG flat cable is also available for combining three-phase current and dimming signal.



SAFETY

With directly pluggable luminaires there is no need to open them for electrification. This means that the industrial manufacturing standard can also be maintained on site.



INSTALLATION

Thanks to the completely pluggable design of the installation, there is no need for any cutting, baring, stripping, or clamping of the cables. This makes the installation process easy, quick, and safe.



OPTION

With applications over a large area with long cable lengths, a 7-pole gesis®NRG flat cable is also available.

LIGHTING CABLING (SWITCHED CENTRALLY, 1/3 CIRCUIT)

Centrally controlled light for the area

APPLICATION IN THESE BUILDING TYPES:

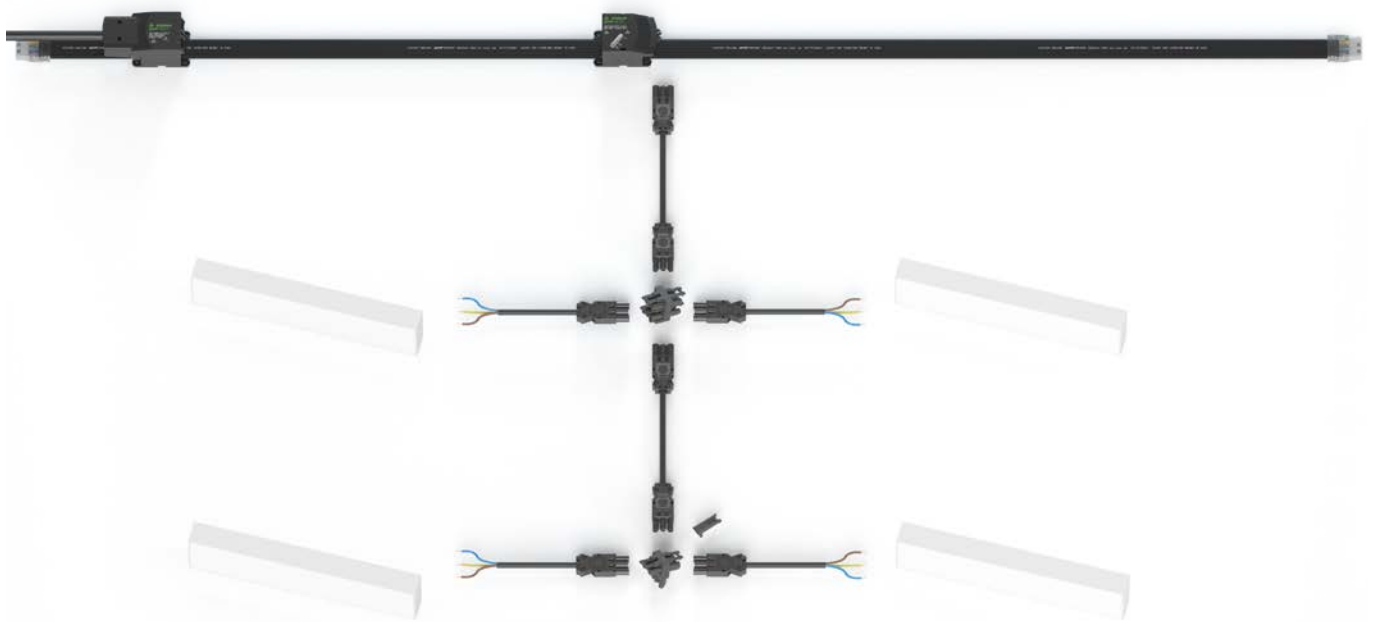

With gesis®NRG in combination with gesis®CLASSIC, it is extremely simple to supply luminaires in large, centrally controlled areas. This allows a flexible choice of connection technology for the luminaires. The usual 1/3 circuit in retail areas can be configured and adapted easily and quickly with the help of the free phase selection of the output adapters of the flat cable.



SAFETY

With directly pluggable luminaires there is no need to open them for electrification. This means that the industrial manufacturing standard can also be maintained on site.



INSTALLATION

Thanks to the completely pluggable design of the installation, there is no need for any cutting, baring, stripping, or clamping of the cables. This makes the installation process easy, quick, and safe.



OPTION

The individual luminaires can be assigned to the luminaire groups via the phase selection of the flat cable tap.

DECENTRALIZED ROOM AUTOMATION (KNX)

Decentralized control/automation reduces the space required for utility rooms

APPLICATION IN THESE BUILDING TYPES:



The decentralized KNX system gesis®FLEX enables room automation to be installed directly on site, saving installation space in utility rooms. The modular setup of the system means that it can be adapted to changing requirements. Ideally, this system is supplied via a 7-pole gesis®NRG flat cable which provides both three-phase current and the KNX network.



RESOURCES

Decentralized assembly of room automation saves space in utility rooms.



INSTALLATION

The instantly available manual control level of the gesis®FLEX modules creates clear interfaces between the various assembly sections.



OPTION

Use of a 7-pole flat cable to supply the modules leads to a clear installation structure.

WINDOW BLINDS (KNX, RELAIS + SMI)

Decentralized control/automation saves cable material

APPLICATION IN THESE BUILDING TYPES:



With the decentralized KNX systems gis®FLEX and gis®EIB V, the effort involved in cabling for sunshade systems can be greatly reduced. Ideally, these actuators are supplied via a 7-pole gis®NRG flat cable which provides both three-phase current and the KNX network. For controlling modern SMI drives there is also a corresponding gis®FLEX KNX SMI gateway.



RESOURCES

Decentralized assembly of sunshade actuators saves a huge amount of cable material.



INSTALLATION

The instantly available manual control level of the gis®FLEX modules creates clear interfaces between the various assembly sections.



OPTION

Use of a 7-pole flat cable to supply the modules leads to a streamline installation structure.

OUR SERVICES + SERVICING PACKAGES

With an extensive range of services and servicing packages, Wieland Electric is a highly capable partner, assisting its customers worldwide with the conception, planning, and implementation of smart electrical installations.

WE ARE WITH YOU ALL THE WAY

- From the first idea through to concept development.
- From the luminaire plan to the cabling concept.
- From the concept to the quantity survey and tendering material and through to the logistics to suit your needs.
- From the configuration and optimization of the system distribution units to their industrial production and through to extensive documentation.

OUR SERVICES

- + CONCEPTION
- + PLANNING
SUPPORT
- + IMPLEMENTATION
- + PROJECT PLANNING
- + OPTIMIZATION
- + REALIZATION
- + PRODUCTION

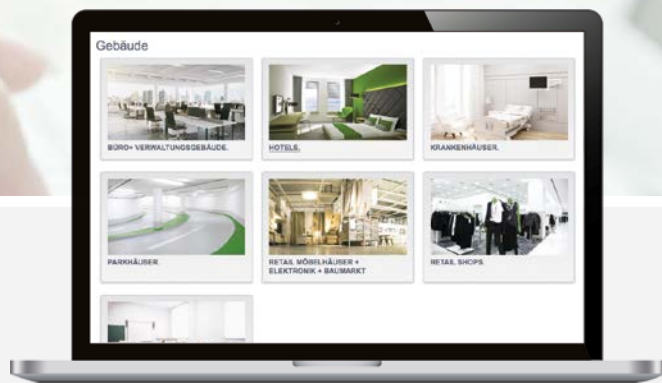

APPLICATION EXAMPLES

On our website you will find application examples for pluggable installation technology in buildings.

**Scan QR code –
watch application examples.**

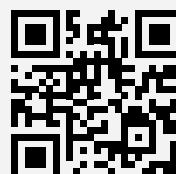

HELLO BUILDING
Online

GESIS® PLAN

THE CONCEPTION TOOL

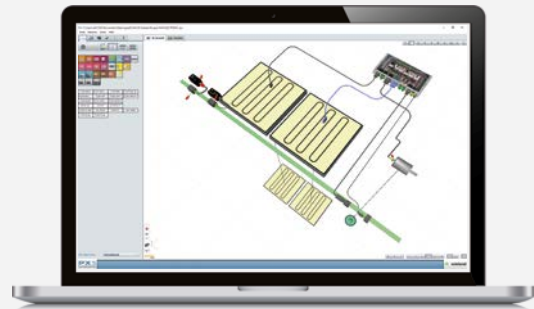

Architects and electrical planners cannot perform their jobs without software planning tools, especially when reliable information regarding project scope, scheduling, and cost estimates is required.

Wieland Electric offers the gesis® PLAN software for conception pluggable electrical installations with gesis®. This conception tool uses CAD building data to generate installation drafts as well as parts and price lists.

gesis® PLAN also independently checks the current load of cables and detects errors. The planner can locate them immediately in the detailed 3D views.

Request gesis® PLAN free of charge:
gesisplan@wieland-electric.com



Wieland on YouTube
See our solutions
in motion



<https://www.youtube.com/user/WielandElectric>



Technical consultation
Building Solutions

Email: building@wieland-electric.com

Worldwide: <https://wie.li/contactinternational>



ONLY ONE TAP AWAY

Our Wieland E-Shop
Over 25,000 products - anytime

In our online store you will find all the information about our products, prices, and technical data.

Order easily and conveniently online, and check availability.

<https://eshop.wieland-electric.com>

Scan QR code –
view products in the
E-SHOP.





wieland

HEADQUARTERS

Wieland Electric GmbH
Brennerstraße 10 – 14
96052 Bamberg · Germany

Phone +49 951 9324-0
Fax +49 951 9324-198
info@wieland-electric.com



0431.1 MC 01/21

Represented in over 70 countries worldwide:

www.wieland-electric.com