

High Accuracy Current Sensors

ORDER STRING (Catalog no.)	CS05S / RS5 (HX0140)	CS1 (EL0072)	CS1L (EL0115)	CS1S (HX0118)
				
MAX CURRENT	20A	100A	100A	100A
WINDOW	Ø 16mm Ø 0.62"	Ø 12mm Ø 0.47"	Ø 23mm Ø 0.9"	Ø 16mm Ø 0.63"
CORE	Split	Solid	Solid	Split
ACCURACY [%]	0.5	0.1	0.1	0.5
WEIGHT	98.2g 0.22 lbs	156.4g 0.34 lbs	206.3g 0.45 lbs	103.4g 0.23 lbs

ORDER STRING (Catalog no.)	CS1H (HX0161)	CS2 (EL0142)	CS2S (HX0145)	CS2SL (HX0156)
				
MAX CURRENT	100A	200A	200A	200A
WINDOW	Ø 13mm Ø 0.5"	Ø 23mm Ø 0.9"	25x23mm 0.96x0.9"	43x33mm 1.69x1.3"
CORE	Split	Solid	Split	Split
ACCURACY [%]	0.1/0.2	0.1	0.5	0.5
WEIGHT	280g 0.6lbs	206.3g 0.45 lbs	160g 0.34lbs	450g 1lbs

ORDER STRING (Catalog no.)	CS250S (HX0166)	CS4 (EL0117)	CS4S (HX0157)
			
MAX CURRENT	250A	400A	400A
WINDOW	24x25mm 0.94x0.98"	Ø 26mm Ø 1.02"	43x33mm 1.69x1.3"
CORE	Split	Solid	Split
ACCURACY [%]	0.5	0.1	0.5
WEIGHT	210g 0.46lbs	214g 0.47lbs	450g 1lbs

ORDER STRING (Catalog no.)	CS4L (EL0153)	CS8 (EL0125)	CS8S (HX0158)
			
MAX CURRENT	400A	800A	800A
WINDOW	Ø 45mm Ø 1.77"	100x32/62mm 4x1.28/2.44"	80x50mm 3.1x1.9"
CORE	Solid	Solid	Split
ACCURACY [%]	0.1	0.1	0.5
WEIGHT	300g 0.66lbs	525g 1.16lbs	900g 1.9lbs

ORDER STRING (Catalog no.)	CS12S (HX0153)	CS20S (HX0154)	CS30S (HX0155)
			
MAX CURRENT	1200A	2000A	3000A
WINDOW	120x80mm 4.7x3.1"	160x80mm 6.3x3.15"	160x80mm 6.3x3.15"
CORE	Split	Split	Split
ACCURACY [%]	0.5	0.5	0.5
WEIGHT	1.25kg 2.75lbs	4.3kg 9.4lbs	4.3kg 9.4lbs

Technical Specifications

Frequency	50/60Hz
Lead Insulation	600V AC
Core Insulation	4000V AC
Nominal Current	50% of maximum current
Lead Length	2.5m / 8.2ft (UL1015)
Operating Temperature	-40°C to +70°C
Storage Temperature	-40°C to +85°C
Material	All materials are UL approved
Standard	IEC 60044-1
Burden	0.2 VA
Thermal over current limit	40×I _{MAX} for 1 second
Short circuit over current	80×I _{MAX} for 10 ms

Installation Recommendations

All HACS include a built-in automatic protection circuit for maximum safety, eliminating the need to use shorting bars.

All HACS are supplied with 8ft / 2.5m cable.

Maximum cable length: 650ft / 200m.

Recommended wire gauge: $\geq 1.5 \text{ mm}^2$

It is recommended to use a shielded extension cable to connect between the HACS and the SATEC meter. The cable shield must be connected to the SATEC meter ground.

It is recommended to locate HACS cable in separate cable conduit and at least 1m (3ft) away from High Voltage circuits, and/or other high power magnetic fields.

CT Dimensions

Order String

**CS05S / RS5
(HX0140)**

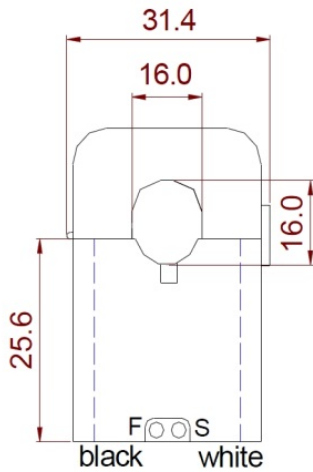

Front view

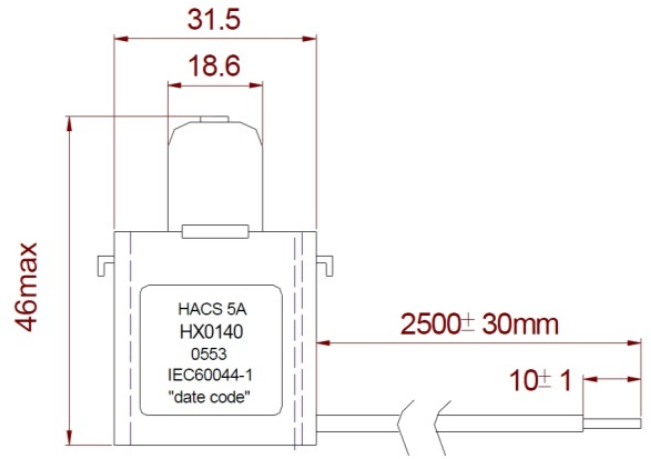

Left view

**CS1
(EL0072)**

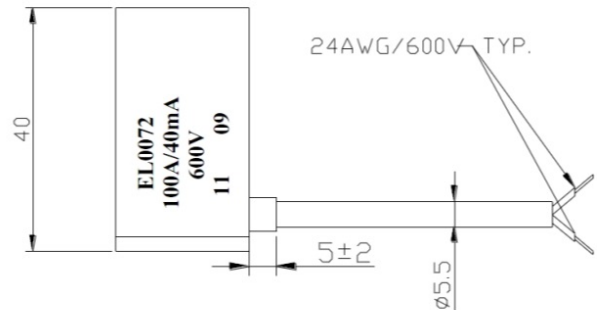
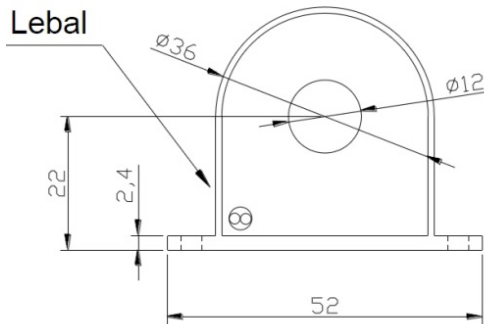

**CS1L
(EL0115)**

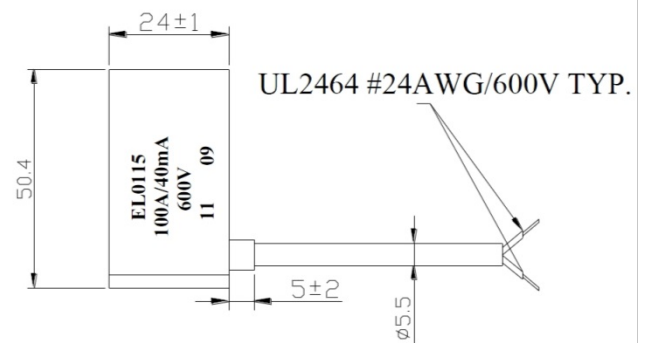
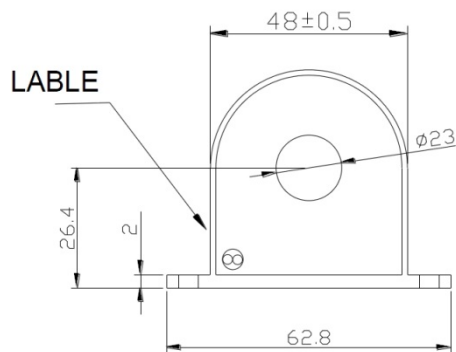

Order String

**CS1S
(HX0118)**

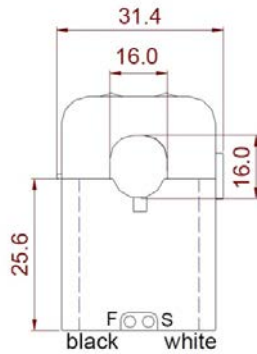

Front view

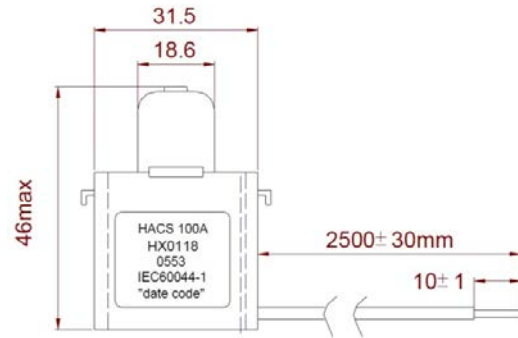

Left view

**CS1H
(HX0161)**

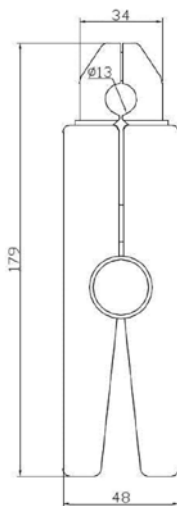

**CS2
(EL0142)**

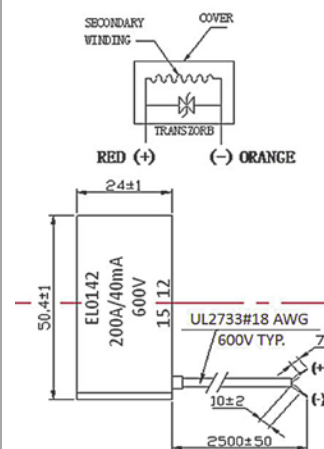
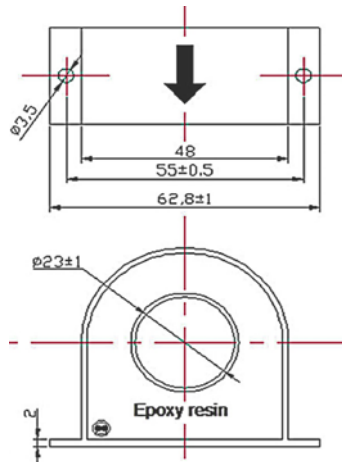

Order String

**CS2S
(HX0145)**

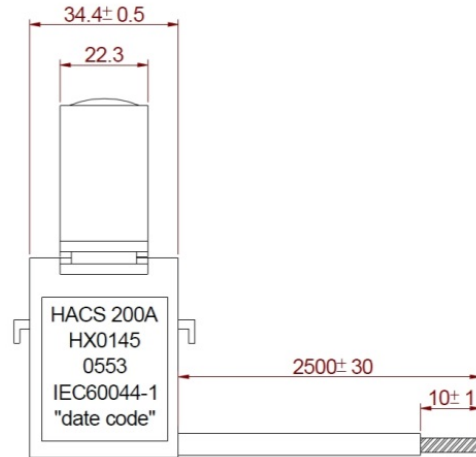
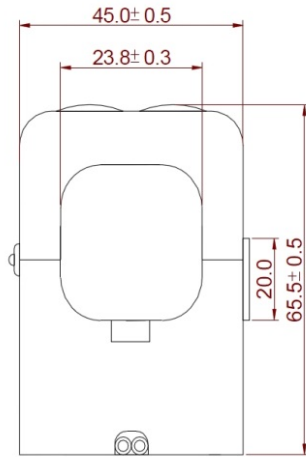

UL1015 22AWG PVC WIRE (600V)

**CS2SL
(HX0156)**

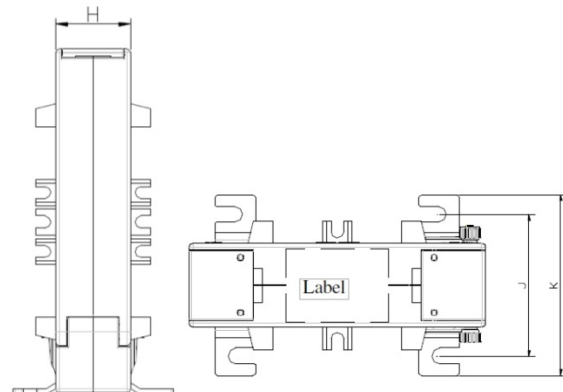
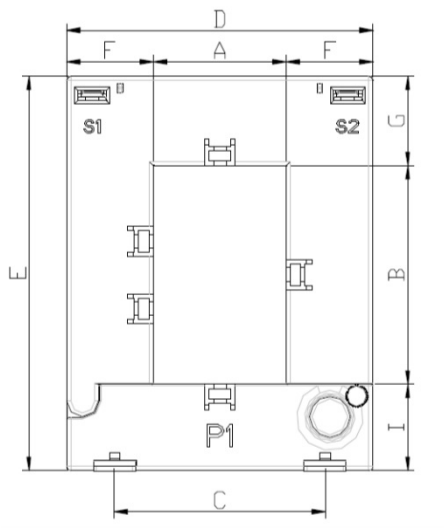

A	B	C	D	E	F	G	H	I	J	K
33	43	45	92	100	29.5	30	28	27	50	65

Order String

**CS250S
(HX0166)**

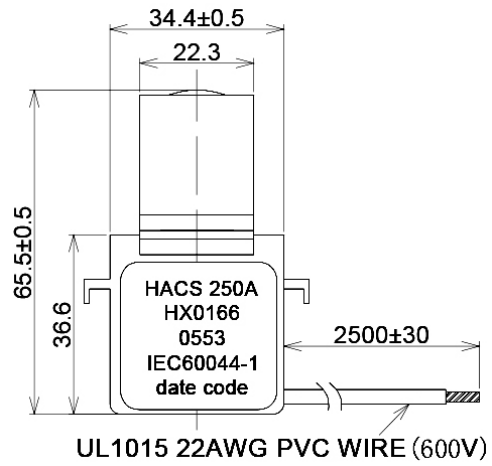
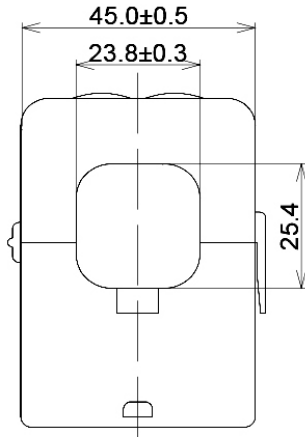

**CS4
(EL0117)**

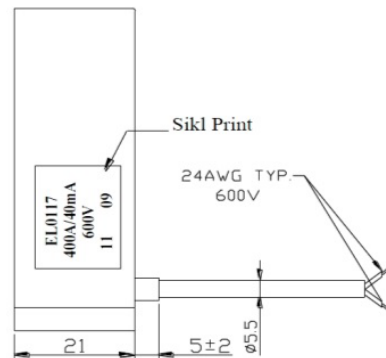
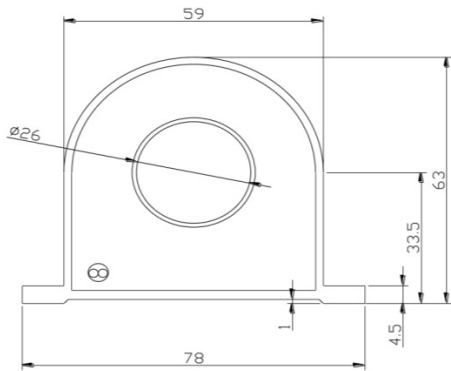

**CS4S
(HX0157)**

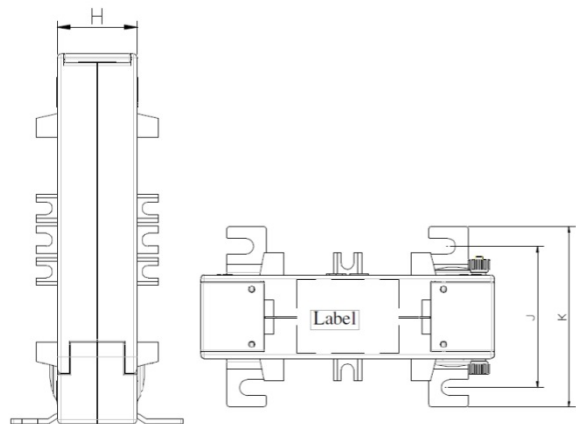
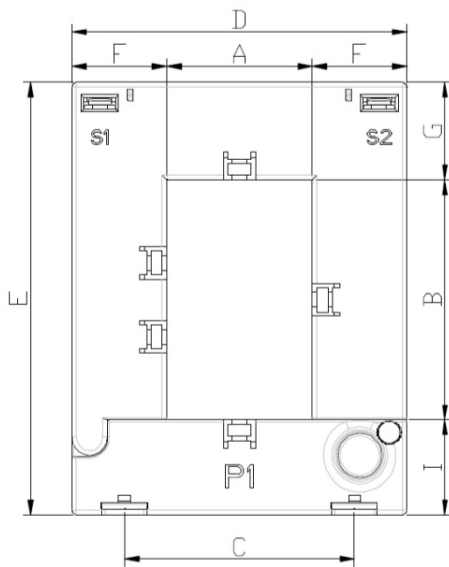

A	B	C	D	E	F	G	H	I	J	K
33	43	45	92	100	29.5	30	28	27	50	65

Order String

**CS4L
(EL0153)**

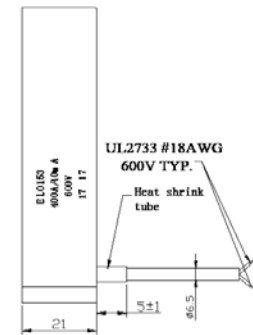
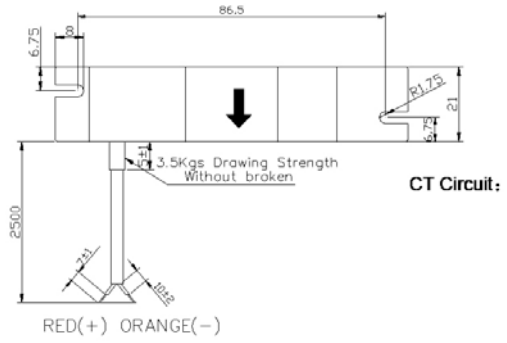
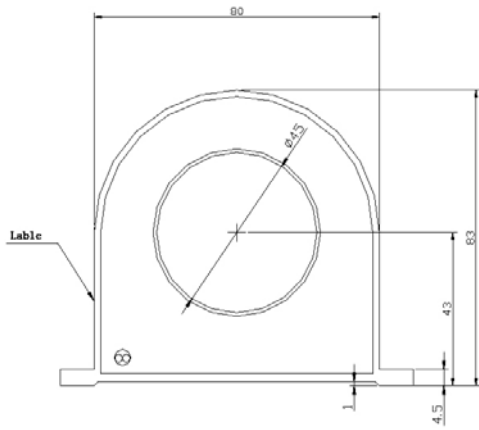

**CS8
(EL0125)**

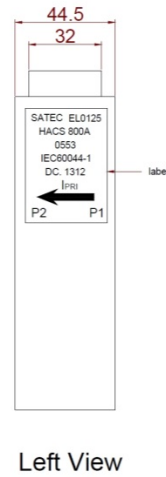
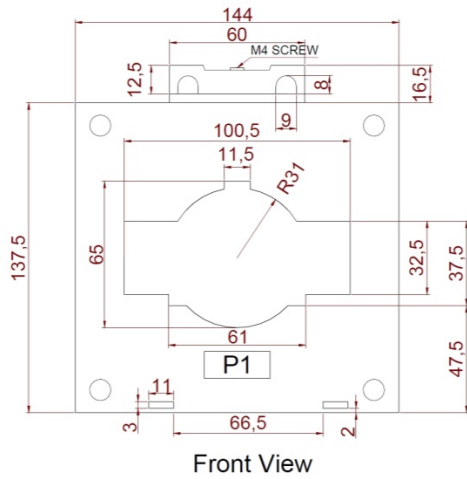

Order String

**CS8S
(HX0158)**

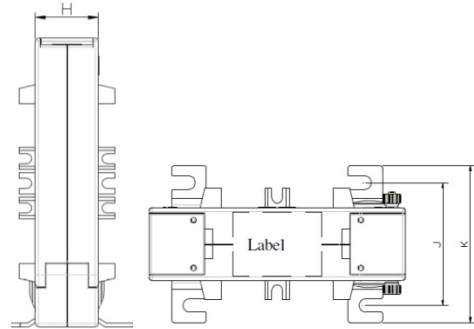
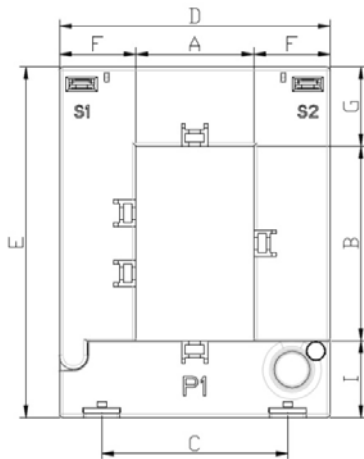

A	B	C	D	E	F	G	H	I	J	K
50	80	78	114	145	32	32	32	33	52.5	67.5

**CS12S
(HX0153)**

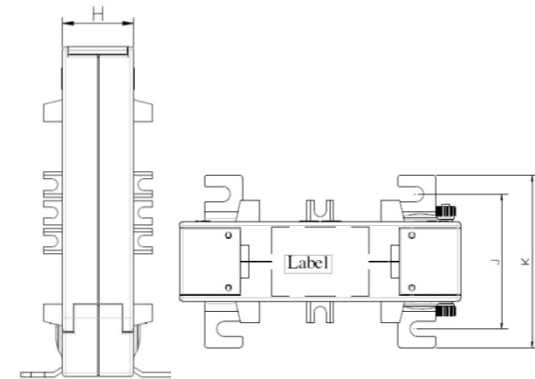
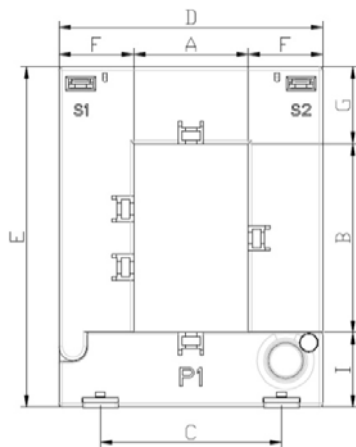

A	B	C	D	E	F	G	H	I	J	K
80	120	108	144	185	32	32	32	33	52.5	67.5

**CS20S
(HX0154)**

**CS30S
(HX0155)**

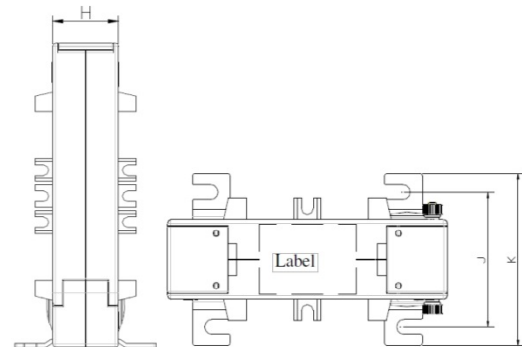
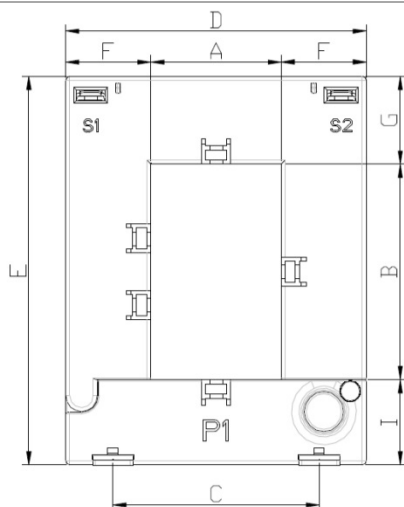

A	B	C	D	E	F	G	H	I	J	K
80	160	120	184	245	52	47	52	38	61	76